

TECHNICAL MANUAL

for the
GLOBE

1961

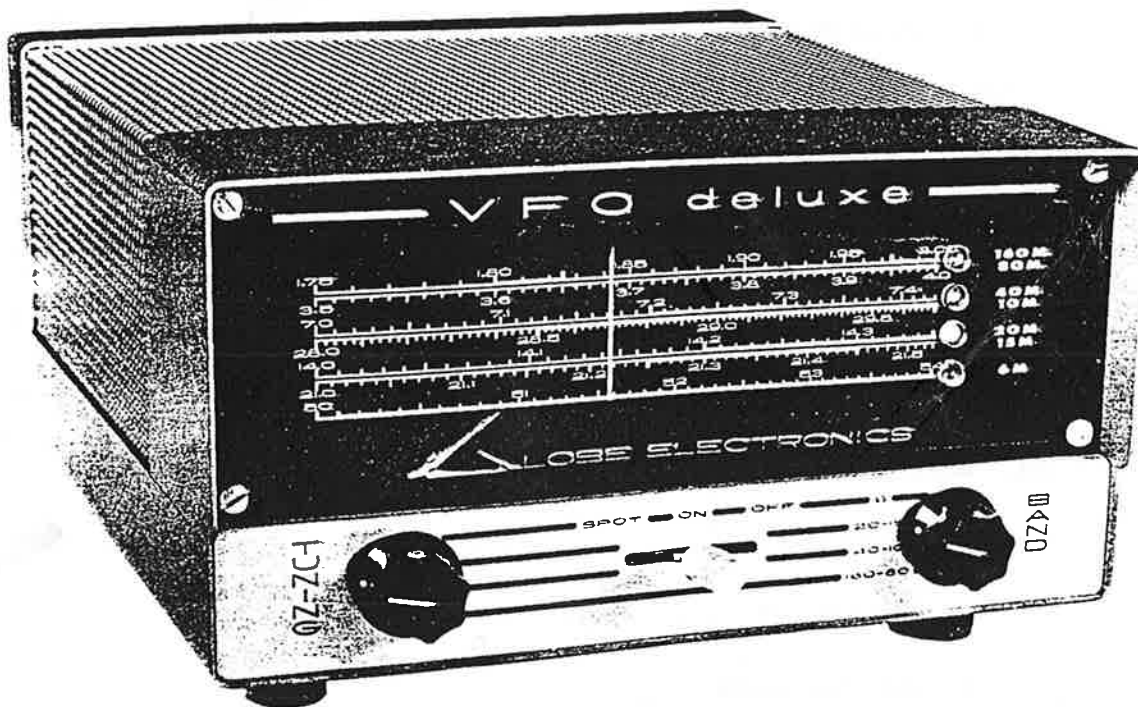

Variable Frequency Oscillator Model V-10

Form FR-028-L

Copyright 1961 Globe Electronics Printed in U.S.A.

GLOBE ELECTRONICS CO.

WESTERN PLANT: LOS ANGELES 18, CALIFORNIA

TABLE OF CONTENTS

FORWARD	2
I. DESCRIPTION	3
1. Introduction	3
2. Design	3
3. Equipment Complement	4
4. Equipment Specifications	4
II. INSTALLATION AND OPERATION	5
1. Preliminary	5
2. Pre-operational Check	5
A. Description of Controls	5
B. External Connections	5
3. Installation	7
4. Operation	8
III. MAINTENANCE	9
1. Forward	9
2. Alignment	9
3. Service Aids	
A. Parts Identification Top	12
B. Parts Identification Bottom	13
C. Dial Stringing Drawing	14
D. Parts List Schematic, Volume Chart	15
E. Service Stations and Distributors	Inside Back Cover
F. Warranty	Back Cover

1. PURPOSE

The purpose of this manual is to provide the owner and/or serviceman with detailed information for the installation, operation and maintenance of the equipment. It is suggested that this manual be thoroughly read and understood before any attempt is made to place the equipment in operation.

2. PRODUCTION CHANGES

From time to time, electrical and/or mechanical changes are made to further improve the product. When a sufficient number of changes have been incorporated to justify a model number change, an A, B, or C, etc., is added to the original model number, i. e., V-10A. When and if such a change is made, a modification kit will be made available to enable the purchaser to update his equipment.

3. MANUAL REVISION BULLETINS

As production changes are made, manual revision bulletins are inserted in the manuals and packed with the equipment. Authorized service stations are also supplied with current bulletins as they appear.

The manual revision bulletins contain such information as type of change, reason for change, circuits affected, parts added and deleted, and a revised schematic.

4. SERVICE ORGANIZATIONS

Located throughout the United States are authorized service stations, which are qualified to repair all equipment manufactured by Globe Electronics. All service stations are also authorized to perform warranty repairs on all equipment. Each service organization has been carefully selected for their competence, quality of service, necessary test equipment and interest to service our products.

Globe Electronics also maintains an efficient service department within the plant for those who wish to return their equipment directly to the factory for modifications or servicing.

5. REPLACEMENT PARTS ORDERING

When ordering replacement parts from either the factory or authorized service stations, always include the Globe part number, description and model number of the equipment, and also the method of shipment desired. Include the serial number of the equipment if the part is to be a warranty replacement. Under no conditions will Globe Electronics accept damaged or defective goods for warranty exchange unless proper authorization from our customer service department has been issued.

I. DESCRIPTION

1. INTRODUCTION

The V-10 consists basically of a seven band, electrically, mechanically and thermally stable variable frequency oscillator to be used in conjunction with CW, AM, or SSB transmitters. It provides a stable output for 160, 80, 40, 20, 15, 10, and 6 meters, covering all portions of each band.

2. DESIGN

Considerable time and effort were spent in the engineering of the V-10 to accomplish the most favorable arrangements of electrical, mechanical, and thermal designs.

A modified Clapp oscillator was chosen because of the series tuned arrangement of the frequency determining circuits, in which case small changes in input capacity of the tube will have little or no effect on frequency. By using electron coupling, frequency variations, due to output loading, were minimized.

All frequency determining components have been completely enclosed in a separate compartment to isolate them from drafts and sudden changes in temperature. The remotely controlled band switch was also enclosed in this compartment to provide short leads to the components it controls.

A sturdy, two section variable capacitor was used to provide maximum band spread and stability on all bands.

Temperature compensation was used liberally to reduce frequency drift during and after warm-up.

A cathode follower stage proceeding the oscillator, isolates the oscillator from the buffer amplifier, while the broadband buffer amplifier provides amplification and also isolation from the transmitter.

Voltage regulation is used in all voltage sensitive circuits. The unit contains its own power supply, thereby enabling it to be used with all types of equipment.

An illuminated slide rule dial was incorporated to facilitate tuning. Also incorporated are colored illuminated indicators to show at a glance which band is currently in operation.

A separate SPOT-ON-OFF, spring return, lever switch enables ZERO BEATING with another station.

3. EQUIPMENT COMPLEMENT

The Globe Electronics V-10 VFO, as supplied, consists of the basic VFO, coaxial cable complete with RCA phono plug and crystal socket plug, operating manual and a two circuit phone plug.

4. EQUIPMENT SPECIFICATIONS

Frequency Coverage: 1.75 to 2.0 mc (160 & 80 meters), 7.0 to 7.425 mc (40 & 10 meters), 7.0 to 7.175 mc (20 & 15 meters), 8.333 to 9.0 mc (6 meters).

Minimum Output Voltage (P. P.)
140V

Maximum Frequency Drift (after 20 minutes warm up period)
100cps

Power Consumption (watts)
15w

Height	4 inches
Width	9-1/8 inches
Depth	9-1/2 inches
Weight	9 pounds

II INSTALLATION AND OPERATION

1. PRELIMINARY

Carefully unpack and examine the equipment for any damage. Should any damage have occurred, report it to the carrier -- NOT TO GLOBE ELECTRONICS. The carrier will supply you with the proper forms and instruct you in obtaining repairs or replacement. If no damage is apparent, proceed with the pre-operational check.

2. PRE-OPERATIONAL CHECK

Description of controls:

Bandswitch - Permits instant selection of band of operation; 160 through 6 meters. The Bandswitch has four positions: 160-80 M, 40-10 M, 15-20 M, and 6 meters.

Tuning - Tunes the VFO to the desired frequency after the band has been selected.

SPOT-ON-OFF - When this switch is in the OFF position, AC power is removed from the VFO. In the ON position, the switch completes the primary circuit of the power transformer and power is applied to the VFO. In the SPOT position, the switch completes the cathode circuit of the oscillator, thus permitting the operator to "zero beat" a received signal without turning on the transmitter.

External Connections

WARNING - Before making any external connections to the VFO or between the VFO and the transmitter, remove the AC line cord plug from the AC outlet. Also, place the lever switch on the VFO in the OFF position and all transmitter

switches in the OFF position.

Key Jack - Located on the rear apron and used for keying of the VFO.

Output Jack - Located on the rear apron and used for output cable connection to the transmitter.

Power Cord - Located on the rear apron and used to supply AC power to the VFO.

AC Fuse - Located on the rear apron and requires a 1.5 A., 250v fuse.

The pre-operational check as outlined, must only be followed before the equipment is placed into initial operation. Once they have been preformed, they may be disregarded.

The V-10 is very well shielded, as is a good receiver. In the following checks it may be necessary to bring a wire from the output jack and place it near the antenna terminals of the receiver if a suitable strong signal cannot be received.

- A. Place the lever switch in the OFF position.
- B. Insert the power cord plug into an AC outlet.
- C. Place the lever switch in the ON position. Allow a few minutes for the equipment to warm up.
- D. Place the band switch in the 160-80 meter position.
- E. Set the VFO dial pointer to 3.8mc.
- F. Turn on the receiver BFO and set the receiver to 3.8 mc.
- G. Place the lever switch in the SPOT position.
- H. Rock the tuning knob of the VFO so the dial pointer moves across the 3.8mc point on the dial. An audible tone that varies in pitch, should be heard in the receiver as the VFO is tuned across the frequency to which the receiver is tuned.
- I. Place the band switch in the 40-10 meter position.
- J. Tune the receiver to 7.1 mc.
- K. Place the lever switch in the SPOT position and rock the tuning knob so the pointer moves across the 7.1 mc point. An Audible tone should be heard as in step "H".
- L. Place the band switch in the 20-15 meter position.
- M. Leave the receiver tuned to 7.1 mc.
- N. Proceed as in step "K".
- O. Place the band switch in the 6 meter position.
- P. Tune the receiver to 8.666 mc.
- Q. Place the lever switch in the SPOT position and rock the tuning knob across the 52 mc point. An audible tone should be heard as in preceding steps. If the receiver will not tune 8.666 mc, but will tune 52 mc. check at this frequency with close coupling between the VFO and receiver.

If all checks up to this point are satisfactory, the VFO may be connected to the transmitter.

3. INSTALLATION

- A. Insert the RCA phono plug (attached to the coaxial cable supplied) into the OUTPUT jack on the rear apron of the VFO.
- B. Insert the other end into the crystal socket on the transmitter making certain that the grounded pin in the plug mates with the grounded pin in the crystal socket.

IMPORTANT

Approximately three feet of RG/59U is supplied with the equipment. A RCA type Phono connector is assembled on one end. This cable should be cut to as short a length as possible, and a suitable plug (a crystal socket plug is supplied which will be used in most installations) assembled on the other end. Only in extreme cases should the full length of cable, as supplied, be used.

For optimum drive, each band should be peaked, with the VFO connected to the transmitter, as follows:

Place the dial pointer in the center of the scale. Select the band to be peaked and adjust the proper output coil for maximum drive as indicated on the grid current meter on the transmitter.

Note: L-5 160-80M, L-6, 40M, 20M, 15M, 10M, L-7-6M.

C. The phone jack on the rear apron provides for keying the VFO or placing it in stand-by during non-transmit periods. The tip connection on the phone plug must be keyed to ground only, in order to operate the VFO. This may be accomplished with a telegraph key for CW or a switch or relay on the transmitter for push-to-talk AM operation. (See figures A & B)

4. OPERATIONS

Operation of the V-10 is quite simple once the proper connections to the transmitter have been made. Merely select the band you wish to use and then select the frequency by zero beating with another station or by using the dial calibrations.

The transmitter will have to be retuned each time you change bands and also when a large frequency change within a band is made. This will depend on the particular transmitter being used.

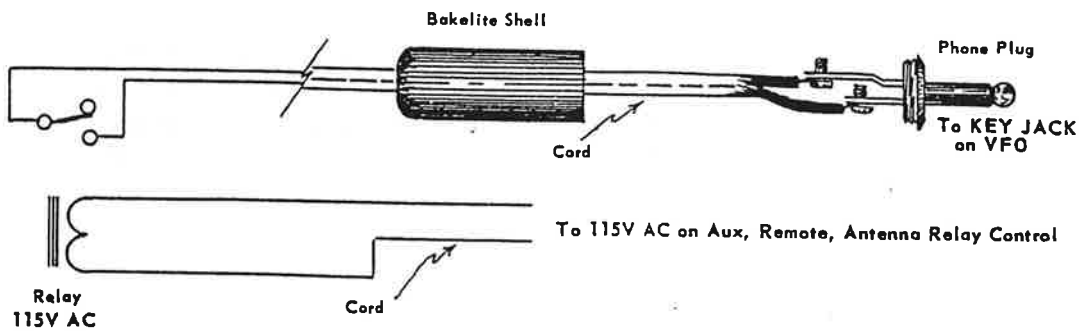

Fig. A

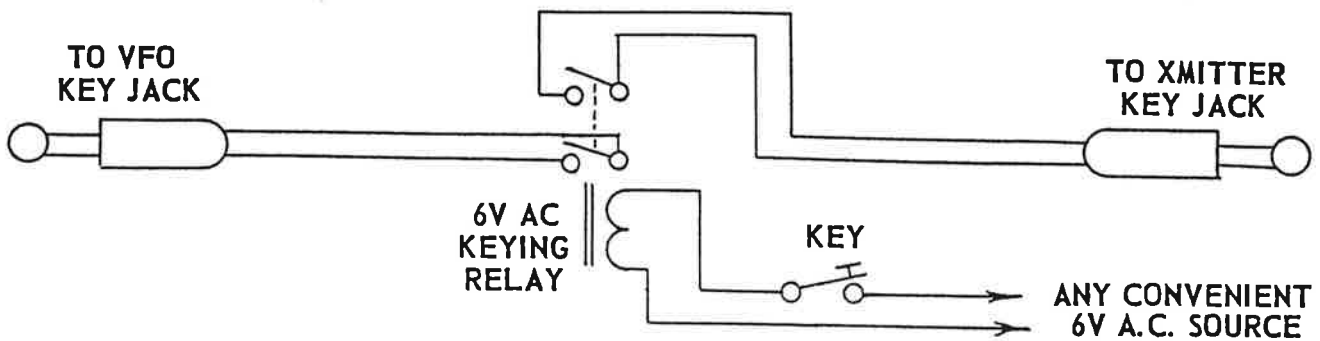

Fig. B

SECTION III

MAINTENANCE

1. FORWARD

The design and manufacturer of this unit is such that it should require little or no servicing. The following section, however, contains information to aid in rapid servicing, should the need arise.

Should alignment become necessary due to the replacement of a tube or component, the following procedure should be followed to produce the best results.

NOTE: If only one band is in need of calibration, it is unnecessary to perform the alignment steps for the other bands.

2. ALIGNMENT

- A. Adjust trimmers C-4, C-7, C-10, and C-13 to the "half open" position in such a manner that further rotation of the shaft, in a clockwise direction, will decrease the capacitance.
- B. Adjust the slugs in coils L-1, L-2, L-3, and L-4 to the point where they just start to enter the winding.
- C. Adjust the main tuning capacitor so that the plates are fully meshed. If the tuning plates cannot be fully closed or they rotate past the fully closed position, the set screw locking the gear on the capacitor shaft will have to be loosened and repositioned so the capacitor stops in the proper position. Also, make certain the dial pointer lines up with the first calibration mark on the dial scale when the plates are fully closed.
- D. Rotate the tuning knob clockwise to the limit of its rotation. The dial pointer should now line up with the last calibration mark on the scale. NOTE: The plates of the tuning capacitor will not be fully open since the stops limit the rotation to 160° .
- E. Place the cover on the oscillator shield and fasten all screws.
- F. Insert the power cord plug into a 115 V AC outlet and place the lever switch in the ON position. Allow approximately 15 to 20 minutes for the unit to completely stabilize. Connect a closed key or shorting plug in the KEY jack while the unit is warming up.

- G. Place the unit on its side and rotate the band switch to the 160-80 meter position.
- H. Rotate the tuning knob to its maximum counter-clockwise position. (1.75/3.5 mc)
- I. Set the dial of a good communications receiver of known accuracy, to 3.5 mc. Turn on the receiver BFO.
- J. Adjust the slug of L-1 in a clockwise direction (core entering the coil) until the VFO's signal is heard in the receiver. Continue adjusting the slug until the signal zero beats in the receiver.
- K. Retune the receiver to 4.0 mc.
- L. Retune the VFO to 2.0/4.0 mc.
- M. Adjust trimmer C-4 for zero beat in the receiver.
- N. Repeat steps H, I, J, K, L, M as many times as necessary, until the 3.5 and 4.0 mc points on the VFO correspond to the same points on the receiver.
- O. Place the VFO Band switch in the 40-10 meter position.
- P. Tune the receiver and VFO to 7.0 mc.
- Q. Adjust the slug of coil L-2 for zero beat in the receiver, by turning it in a clockwise direction.
- R. Tune the receiver and VFO to 7.425 mc.
- S. Adjust trimmer C-7 for zero beat in the receiver.
- T. Repeat steps P through S (incl.) as many times as necessary to make the 7.0 and 7.425 mc points on the VFO dial correspond to the same points on the receiver dial.
- U. Place the VFO band switch in the 20-15 meter position.
- V. Tune the receiver to 7.0 mc and the VFO to 14.0 mc.
- W. Adjust the slug in coil L-3 in a clockwise direction until a zero beat is heard in the receiver.
- X. Tune the receiver to 7.125 mc and the VFO to 14.350 mc.
- Y. Adjust trimmer C-10 for zero beat.
- Z. Repeat U through Y (incl.) as many times as is necessary to make the 14.0 and 14.350 mc points on the VFO correspond to the 7.0 and 7.125 mc points on the receiver.

- AA. Place the VFO band switch in the 6 meter position. ^{8.988}
- BB. Tune the receiver to ~~8.333~~ mc and the VFO to 50.0 mc. ←
- CC. Adjust the slug in coil L-4 in a clockwise direction until a zero beat is heard.
- DD. Tune the receiver to ^{9.085}~~9.0~~ mc and the VFO to 54.0 mc. ←
- EE. Adjust trimmer C-13 for zero beat in the receiver.
- FF. Repeat steps BB through EE (incl.) as many times as is necessary to make the 50 and 54 mc points on the VFO dial correspond to the 8.333 and 9.0 mc points on the receiver dial.
- GG. This completes the oscillator alignment. Output coils L-5, L-6 and L-7 should be adjusted for maximum output after being connected to the stage to be driven.

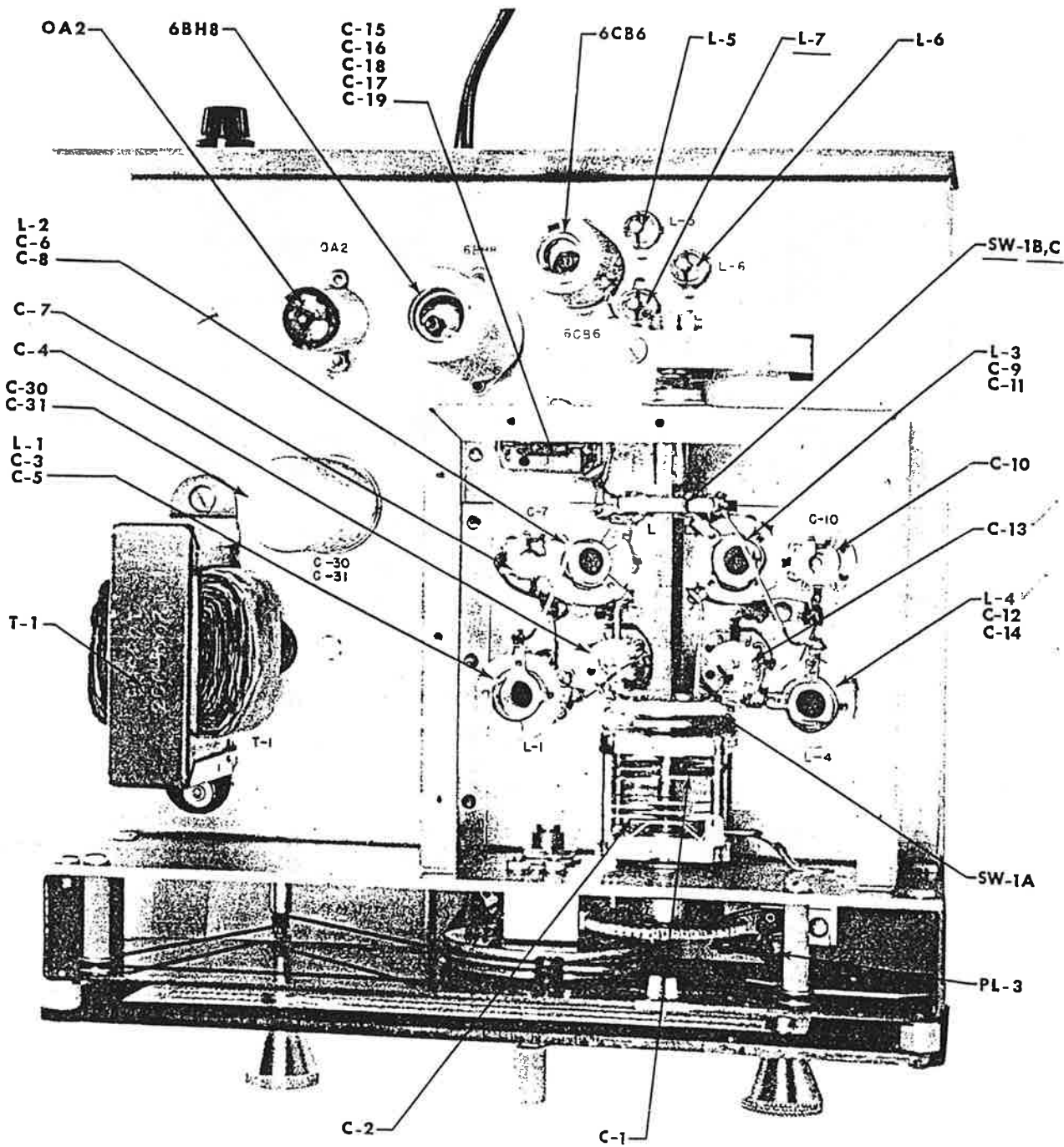

FIG. C

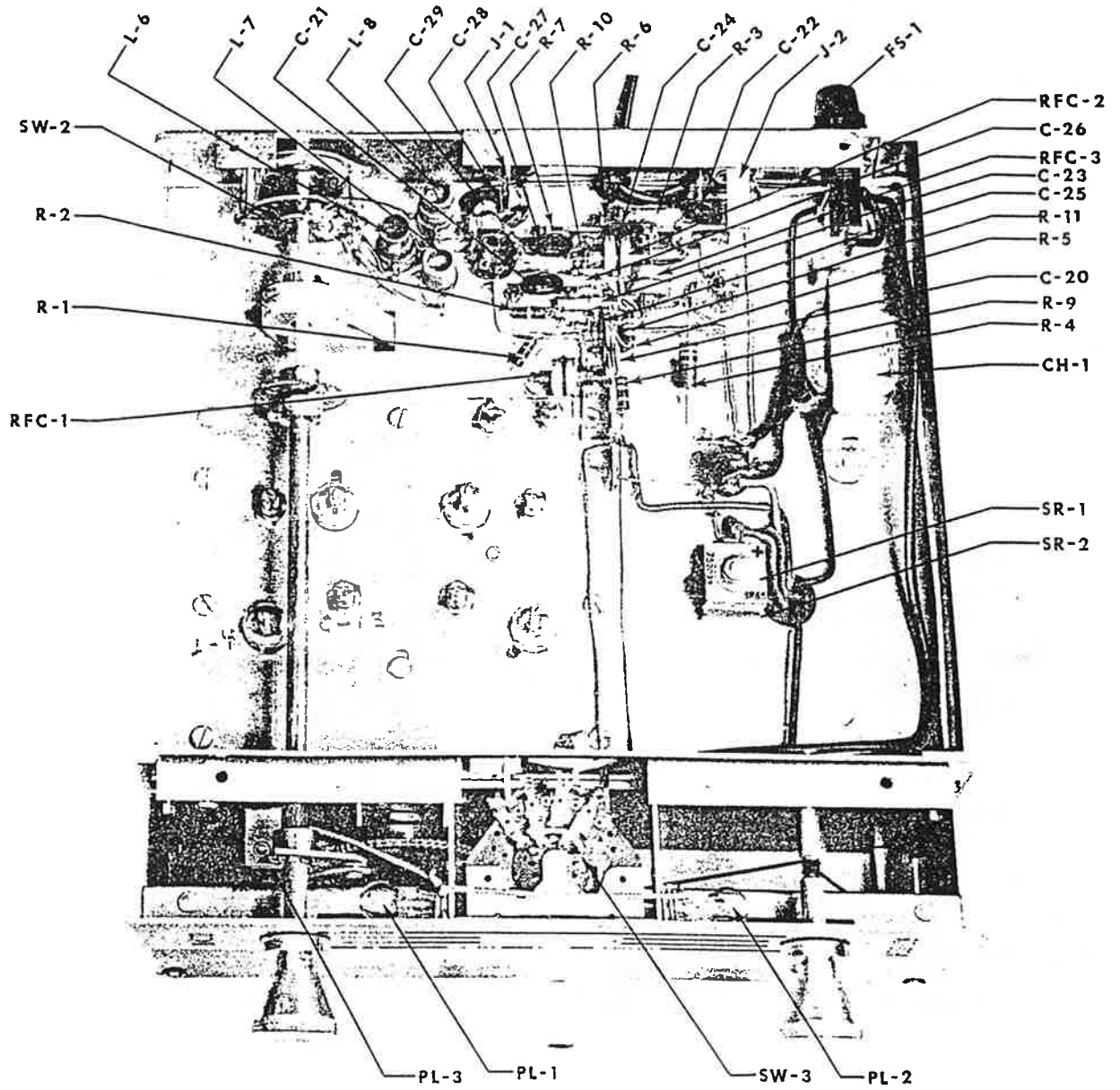
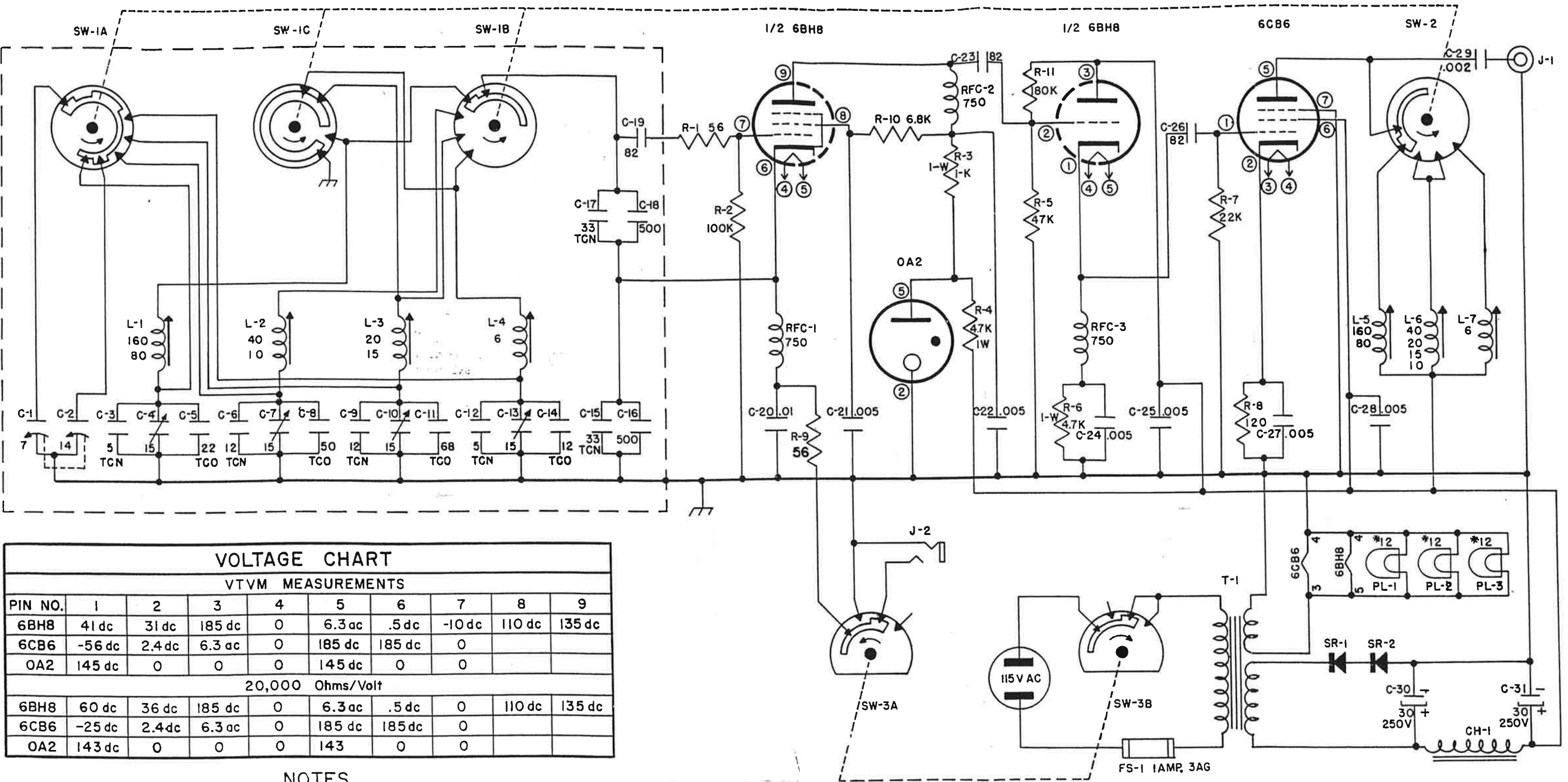

FIG. D



VOLTAGE CHART

VTVM MEASUREMENTS

PIN NO.	1	2	3	4	5	6	7	8	9
6BH8	41 dc	31 dc	185 dc	0	6.3 ac	.5 dc	-10 dc	110 dc	135 dc
6CB6	-56 dc	2.4 dc	6.3 ac	0	185 dc	185 dc	0		
OA2	145 dc	0	0	0	145 dc	0	0		
20,000 Ohms/Volt									
6BH8	60 dc	36 dc	185 dc	0	6.3 ac	.5 dc	0	110 dc	135 dc
6CB6	-25 dc	2.4 dc	6.3 ac	0	185 dc	185 dc	0		
OA2	143 dc	0	0	0	143	0	0		

NOTES

1. ALL RESISTORS 1/2 WATT UNLESS OTHERWISE STATED.
2. ALL CAPACITOR VALUES ARE MMFD. EXCEPT THOSE STATED IN DECIMALS WHICH ARE MFD.
3. VOLTAGE MEASUREMENTS IN BOTH CHARTS MEASURED WITH LINE VOLTAGE 115 VAC, LEVER SWITCH IN 'SPOT' POSITION, AND BANDSWITCH IN '160-80M' POSITION.

VFO deluxe
MODEL: V-10